

SUFON MOTOR

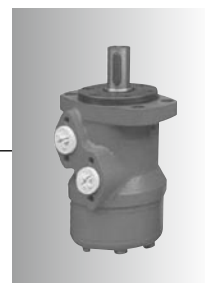

BMR SERIES HYDRAULIC MOTOR

BMR series motor adapt the advanced Gerolor gear set design with shaft distribution flow, which can automatically compensate in operating with high pressure, provide reliable and smooth operation, high efficiency and long life.

Characteristic features:

- *Advanced manufacturing devices for the Gerolor gear set, which use low pressure of start-up, provide smooth, reliable operation and high efficiency.
- *Shaft seal can bear high pressure of back and the motor can be used in parallel or in series.
- *Special design in the driver-linker and prolong operating life
- *Special design for distribution system can meet the requirement of low noise of unit.
- *Compact volume and easy installation

Main Specification

Technical data for BMR with 25 and 1 in and 1 in splined and 28.56 tapered shaft

Type		BMR BMRS 36	BMR BMRS 50	BMR BMRS 80	BMR BMRS 100	BMR BMRS 125	BMR BMRS 160	BMR BMRS 200	BMR BMRS 250	BMR BMRS 315	BMR BMRS 375
Geometric displacement (cm ³ /rev.)		36	51.7	81.5	102	127.2	157.2	194.5	253.3	317.5	381.4
Max. speed (rpm)	cont.	1250	960	750	600	475	378	310	240	190	155
	int.	1520	1150	940	750	600	475	385	300	240	190
Max. torque (N•m)	cont.	72	100	195	240	300	360	360	390	390	365
	int.	83	126	220	280	340	430	440	490	535	495
	peak	105	165	270	320	370	460	560	640	650	680
Max. output (kW)	cont.	8.5	9.5	12.5	13.0	12.5	12.5	10.0	7.0	6.0	5.0
	int.	9.8	11.2	15.0	15.0	14.5	14.0	13.0	9.5	9.0	8.0
Max. pressure drop (MPa)	cont.	14.0	14	17.5	17.5	17.5	16.5	13	11	9	7
	int.	16.5	17.5	20	20	20	20	17.5	15	13	10
	peak	22.5	22.5	22.5	22.5	22.5	22.5	22.5	20	17.5	15
Max. flow (L/min)	cont.	45	50	60	60	60	60	60	60	60	60
	int.	55	60	75	75	75	75	75	75	75	75
Weight (kg)		6.5	6.7	6.9	7	7.3	7.6	8.0	8.5	9.0	9.5

* Continuous pressure:Max.value of operating motor continuously.

* Intermittent pressure:Max.value of operating motor in 6 seconds per minute .

* Peak pressure:Max.value of operating motor in 0.6 second per minute.

SUFON MOTOR

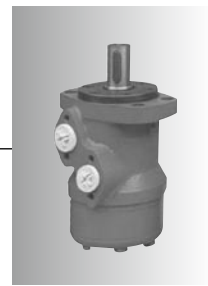

Main Specification

Technical data for BMR with 31.75 and 32 shaft

Type		BMR BMRS 36	BMR BMRS 50	BMR BMRS 80	BMR BMRS 100	BMR BMRS 125	BMR BMRS 160	BMR BMRS 200	BMR BMRS 250	BMR BMRS 315	BMR BMRS 375
Geometric displacement (cm ³ /rev.)		36	51.7	81.5	102	127.2	157.2	194.5	253.3	317.5	381.4
Max. speed (rpm)	cont.	1250	960	750	600	475	378	310	240	190	155
	int.	1520	1150	940	750	600	475	385	300	240	190
Max. torque (N•m)	cont.	72	100	195	240	300	380	450	540	550	580
	int.	83	126	220	280	340	430	500	610	690	690
	peak	105	165	270	320	370	460	560	710	840	830
Max. output (kW)	cont.	8.5	9.5	12.5	13.0	12.5	12.5	11.0	10.0	9.0	7.5
	int.	9.8	11.2	15.0	15.0	14.5	14.0	13.0	12.0	10.0	9.0
Max. pressure drop (MPa)	cont.	14.0	14	17.5	17.5	17.5	17.5	17.5	17.5	13.5	11.5
	int.	16.5	17.5	20	20	20	20	20	20	17.5	15
	peak	22.5	22.5	22.5	22.5	22.5	22.5	22.5	22.5	21	17.5
Max. flow (L/min)	cont.	45	50	60	60	60	60	60	60	60	60
	int.	55	60	75	75	75	75	75	75	75	75
Weight (kg)		6.5	6.7	6.9	7	7.3	7.6	8.0	8.5	9.0	9.5

* Continuous pressure:Max.value of operating motor continuously.

* Intermittent pressure:Max.value of operating motor in 6 seconds per minute .

* Peak pressure:Max.value of operating motor in 0.6 second per minute.

SUFON MOTOR

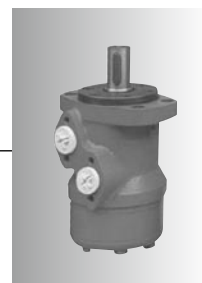

Performance Data

BMR 36 [36cm³/rev.]

Pressure (MPa)

		Max.cont. Max.int.								
		2	3	5	7	9	10	12.5	14.0	16.5
Flow (L/min)	4	10	16	25	37	46	50			
		105	100	92	80	71	58			
8		9	15	25	37	47	50	63	71	83
		208	200	188	175	158	149	134	120	108
15		8	14	23	36	45	51	64	72	82
		403	392	380	365	348	326	318	302	274
20		6	13	22	35	44	50	64	72	82
		540	531	518	500	483	462	450	435	412
30		6	12	21	32	42	47	63	70	80
		810	798	780	763	742	722	705	694	668
40		5	11	19	30	41	45	61	68	79
		1092	1080	1069	1056	1042	1028	1011	984	957
Max.cont.	45	4	10	17	29	40	44	59	66	77
		1230	1215	1194	1170	1150	1128	1100	1070	1020
Max.int.	55		8	15	26	35	40	55	61	72
			1500	1478	1450	1420	1387	1356	1329	1299

BMR 50 [51.7cm³/rev.]

Pressure (MPa)

		Max.cont. Max.int.								
		5	7	9	10	12	14	16	17.5	
Flow (L/min)	5	35	45	61	67	77	88			
		93	84	76	73	69	46			
10		36	46	62	69	80	95	108	120	
		186	178	166	162	153	136	118	97	
15		35	49	63	73	88	100	109	123	
		283	277	269	261	250	230	211	185	
20		34.5	47	61	69	83	96	109	126	
		377	375	365	361	346	330	302	270	
30		33	44	60	67	80	95	108	126	
		576	569	561	554	542	531	500	465	
40		30	41	58	66	79	92	106	122	
		760	758	753	750	738	724	700	670	
45		29.5	40	57	65	78	90	105	121	
		856	853	849	845	835	815	796	770	
50		26	37	53	60	73	85	99	114	
		950	940	925	906	880	852	832	801	
Max.int.	60	20	33	48	56	69	81	95	109	
		1138	1124	1100	1075	1056	1028	1006	970	

BMR 80 [81.5cm³/rev.]

Pressure (MPa)

		Max.cont. Max.int.								
		5	7	9	10	12	14	16	17.5	20
Flow (L/min)	5	50	64	88	108	133				
		59	56	50	44	38				
10		54	77	99	108	129	150	173		
		118	113	106	97	86	79	56		
20		57	78.0	102	111	134	155	177	196	225
		238	234	227	216	203	190	178	154	135
30		54	75	100	108	131	152	176	195	223
		360	352	340	332	316	302	290	274	250
40		48	73	96	105	127	148	172	190	220
		480	470	458	445	430	418	403	388	359
50		42	70	93	102	124	147	170	188	218
		604	595	582	570	556	540	521	504	487
60		37	66	89	98	121	144	166	184	213
		726	715	704	692	678	663	647	622	594
70		32	60	83	95	116	140	160	177	208
		845	834	820	802	789	767	754	730	705
Max.int.	75	21	50	78	90	111	135	154	171	200
		910	895	881	867	852	830	806	787	756

BMR 100 [102cm³/rev.]

Pressure (MPa)

		Max.cont. Max.int.								
		5	7	9	10	12	14	16	17.5	20
Flow (L/min)	5	66	92	120	135	156				
		45	42	38	34	27				
10		68	96	125	138	159	188	212		
		93	90	86	81	74	57	42		
20		65	94.0	123	137	155	186	210	238	274
		189	185	180	173	165	158	150	139	118
30		63	92	120	133	153	185	209	235	270
		286	281	275	266	257	246	237	225	207
40		57	88	117	130	152	185	208	233	267
		385	378	365	355	345	332	320	314	297
50		48	79	110	123	150	183	204	228	260
		482	477	470	460	448	435	420	405	389
60		38	70	105	120	144	178	200	220	252
		580	572	560	548	535	523	510	500	478
70		32	65	100	118	141	176	197	215	246
		678	670	660	648	638	626	615	606	580
75		23	59	93	111	136	170	192	210	240
		728	720	710	695	681	667	650	634	618

Torque (N•m) 135
Speed (rpm) 830

□ cont.
■ int.

SUFON MOTOR

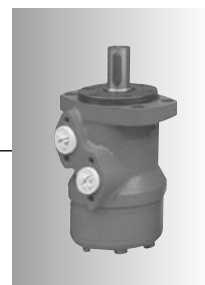

Performance Data

BMR 125 [127.2cm³/rev.]

Pressure (MPa)

	5	7	9	10	12	14	16	17.5	20

Flow (L/min)	Max.cont.									Max.int.
	5	7	9	10	12	14	16	17.5	20	
5	76 36	110 31	145 25	167 19	189 13					
10	84 73	118 70	155 60	176 48	202 36	228 25	253 19			
20	82 153	117 151	153 148	174 144	200 138	230 128	259 117	294 104	332 73	
30	79 231	116 228	151 224	171 218	198 210	228 201	257 183	292 168	329 137	
40	72 309	114 307	148 303	168 298	196 292	226 280	256 270	290 252	327 218	
50	62 389	105 386	143 382	165 378	195 370	223 360	254 344	287 328	323 292	
60	52 467	98 463	136 459	160 456	191 448	220 427	250 410	282 399	319 352	
70	41 545	90 542	130 538	156 534	187 529	215 520	242 508	278 486	313 430	
75	32 586	79 583	126 578	148 570	180 560	208 546	234 532	262 520	300 480	

BMR 160 [157.2cm³/rev.]

Pressure (MPa)

	5	7	9	10	12	14	16	17.5	20

Flow (L/min)	Max.cont.									Max.int.
	5	7	9	10	12	14	16	17.5	20	
5	104 26	146 23	190 20	210 16	245 10					
10	107 59	150 56	195 50	216 45	250 37	290 30	335 22			
20	102 121	151 118	198 115	220 113	257 108	298 102	342 97	370 90	420 78	
30	97 184	146 178	190 173	217 170	256 164	295 155	340 143	368 128	416 103	
40	89 246	140 241	185 235	210 228	250 220	290 210	335 194	363 177	412 150	
50	72 310	128 307	179 300	202 295	244 287	284 278	327 262	358 247	409 210	
60	60 374	116 367	170 359	198 354	240 346	279 338	321 323	352 306	400 265	
70	49 437	107 430	164 421	193 415	233 403	271 393	309 381	344 365	390 318	
75	36 472	98 463	152 450	185 441	226 431	265 420	300 405	334 389	379 365	

BMR 200 [194.5cm³/rev.]

Pressure (MPa)

	5	7	9	10	12	14	16	17.5	20

Flow (L/min)	Max.cont.									Max.int.
	5	7	9	10	12	14	16	17.5	20	
5	132 24	181 22	238 18	262 13	310 10					
10	135 49	186 47	240 45	264 43	315 38	356 33	403 24			
20	131 99	183 97	238 94	260 92	314 88	358 83	404 74	438 64	498 56	
30	126 149	178 147	233 144	254 141	311 135	355 126	402 113	431 105	486 91	
40	112 200	169 197	228 194	250 191	307 185	352 174	400 160	426 151	477 127	
50	95 252	156 249	221 246	246 243	300 238	350 228	398 212	421 194	470 161	
60	78 304	145 301	213 298	238 294	289 286	342 276	386 262	412 243	459 218	
70	67 355	135 353	206 349	228 340	277 329	336 316	375 300	408 288	453 257	
75	58 382	125 379	197 373	220 362	270 350	321 337	360 322	398 312	442 278	

BMR 250 [253.5cm³/rev.]

Pressure (MPa)

	5	7	9	10	12	14	16	17.5	20

Flow (L/min)	Max.cont.									Max.int.
	5	7	9	10	12	14	16	17.5	20	
5	175 17	243 16	304 14	342 12	407 10					
10	178 37	246 35	310 31	344 28	409 23	465 18	525 11			
20	175 75	244 73	308 72	340 70	408 66	463 58	520 53	558 50	636 42	
30	162 114	235 111	304 108	332 106	400 100	455 92	516 83	550 77	621 65	
40	143 154	223 152	300 150	329 147	396 143	447 132	512 120	546 110	617 90	
50	124 193	208 190	289 187	323 174	384 168	440 160	503 149	535 140	600 116	
60	103 233	192 230	280 227	314 224	371 218	426 205	489 190	514 181	578 155	
70	88 273	178 270	264 267	301 263	356 252	418 242	479 226	498 209	560 173	
75	62 294	165 291	256 287	288 283	347 274	412 263	474 249	486 236	542 211	

□ cont.
 □ int.

Torque (N·m) 256
 Speed (rpm) 287

SUFON MOTOR

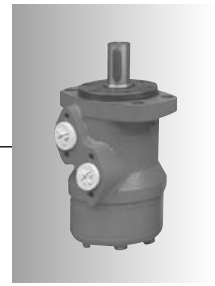

Performance Data

BMR 315 [317.5cm³/rev.]

Pressure (MPa)

	Max.cont.						Max.int.	
	5	7	9	10	12	14	16	17.5

Flow (L/min)	5	215 13	302 11						
	10	218 28	305 27	383 25	422 24	488 21	551 18	622 13	
20	215 60	303 59	380 57	418 55	485 52	549 49	620 45	660 42	
30	204 91	296 89	375 86	413 84	480 81	542 78	613 72	654 67	
40	196 122	287 120	368 117	410 112	477 106	539 100	609 94	650 85	
50	176 154	270 151	356 147	393 140	461 131	526 120	597 109	645 100	
Max.cont. 60	162 185	246 182	339 177	374 172	446 163	511 152	586 140	628 134	
70	143 217	235 213	324 208	358 201	430 190	493 178	562 166	614 158	
Max.int. 75	125 232	212 228	303 222	339 216	417 208	481 200	543 183	582 171	

Torque (N•m) 481
Speed (rpm) 200

BMR 375 [381.4cm³/rev.]

Pressure (MPa)

	Max.cont.						Max.int.	
	3	4.5	5.5	6.5	8	10	12.5	14

Flow (L/min)	5	153 12	232 10						
	10	157 24	236 23	284 22	337 21	406 19	497 17	612 15	668 12
20	150 49	232 48	280 47	332 46	401 44	490 41	606 38	660 32	
30	142 76	215 75	274 74	327 73	398 71	483 67	603 63	652 50	
40	126 103	212 101	268 99	320 97	393 95	477 92	593 88	635 70	
50	105 128	187 126	242 124	302 121	376 118	455 115	583 111	608 96	
Max.cont. 60	90 154	167 152	229 150	281 148	362 145	444 138	566 130	600 121	
70	90 180	149 179	200 178	258 176	341 173	425 168	546 160	580 148	
Max.int. 75	56 195	125 194	182 193	241 191	320 189	408 185	524 178	565 170	

cont.
 int.

SUFON MOTOR

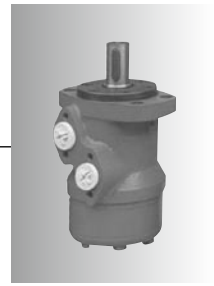

BMR DIMENSIONS AND MOUNTING DATA

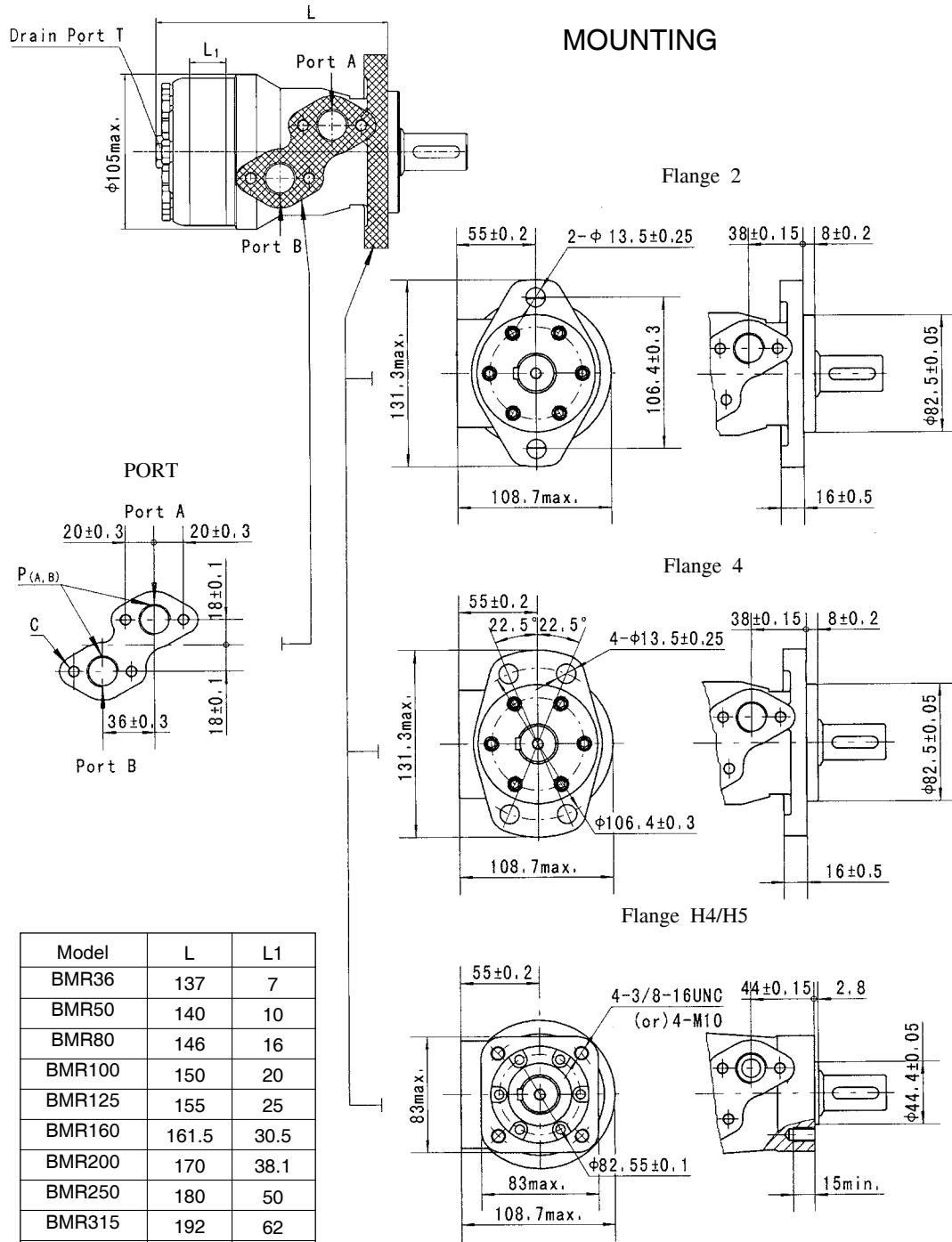

Model	L	L1
BMR36	137	7
BMR50	140	10
BMR80	146	16
BMR100	150	20
BMR125	155	25
BMR160	161.5	30.5
BMR200	170	38.1
BMR250	180	50
BMR315	192	62
BMR375	204	74

Code	D (depth)	M (depth)	S (depth)	P (depth)	R (depth)
P(A,B)	G1/2 (15)	M22 x 1.5 (15)	7/8-14 O-ring (17)	1/2-14NPTF (15)	PT(RC)1/2 (15)
C	4-M8 (13)	4-M8 (13)	4-5/16-18UNC(13)	4-5/16-18UNC(13)	4-M8 (13)
T	G1/4 (12)	M14 x 1.5 (12)	7/16-20UNF (12)	7/16-20UNF (12)	PT(RC)1/4 (9.7)

SUFON MOTOR

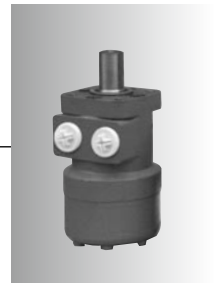

BMRS DIMENSIONS AND MOUNTING DATA

MOUNTING

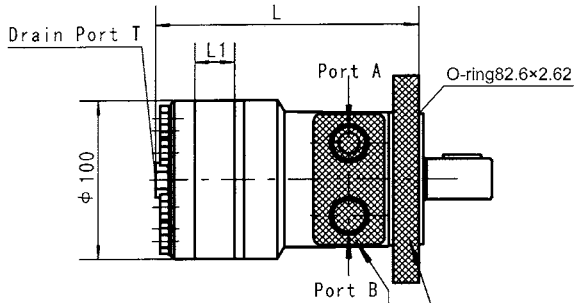

PORT: G, S, P, R, M1, M2, M3

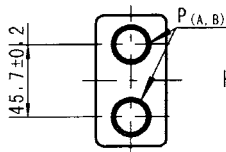

PORT: B4, B5

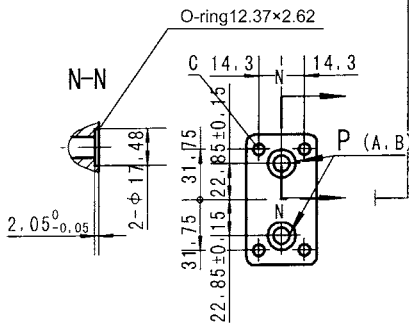

Flange H2

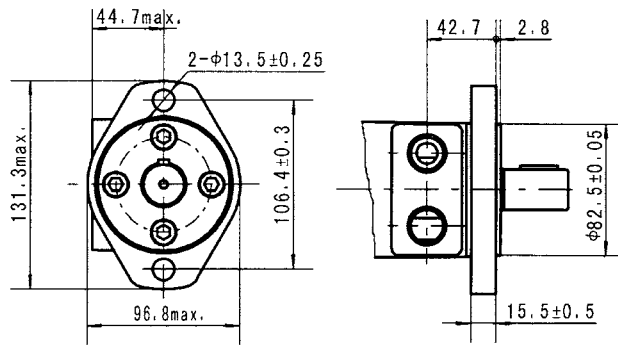

Flange H6

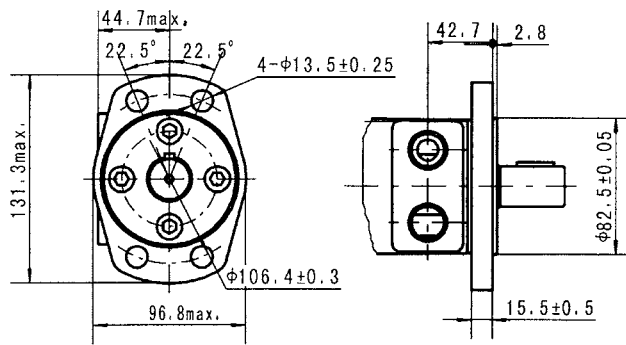

Flange H4/H5

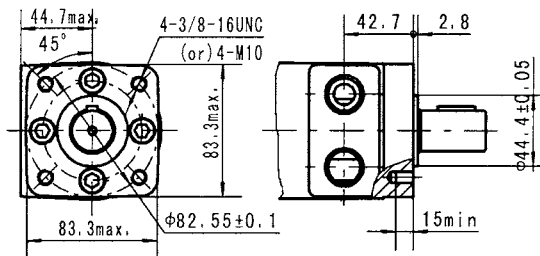

Model	L	L1
BMRS36	141	7
BMRS50	144	10
BMRS80	150	16
BMRS100	154	20
BMRS125	159	25
BMRS160	165.5	30.5
BMRS200	174	38.1
BMRS250	184	50
BMRS315	196	62
BMRS375	208	74

Code Mounting	G (depth)	S (depth)	P (depth)	R (depth)	M1 (depth)	M2 (depth)	M3 (depth)	B4 (depth)	B5 (depth)
P(A,B)	G1/2 (15)	7/8-14 O-ring (17)	1/2-14NPTF (15)	PT(RC)1/2 (15)	M18 x 1.5 (15)	M20 x 1.5 (15)	M22 x 1.5 (15)	ø10	ø10
T	G1/4 (12)	7/16-20UNF (12)	7/16-20UNF (12)	PT(RC)1/4 (9.7)	M10 x 1 (12)	M10 x 1 (12)	M10 x 1 (12)	7/16-20UNF(12)	G1/4(12)
C	-	-	-	-	-	-	-	4-5/16-18UNC(13)	4-M8(13)

SUFON MOTOR

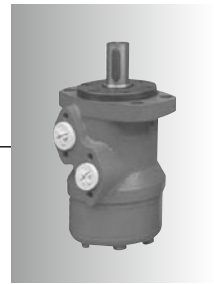

BMR SHAFT EXTENSIONS DIMENSIONS DATA

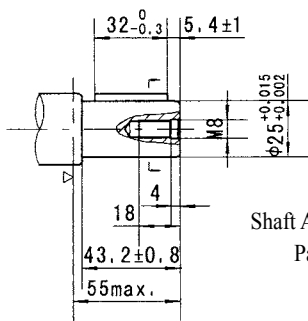

Shaft A: Cylindrical shaft ø25
Parallel key 8x7x32

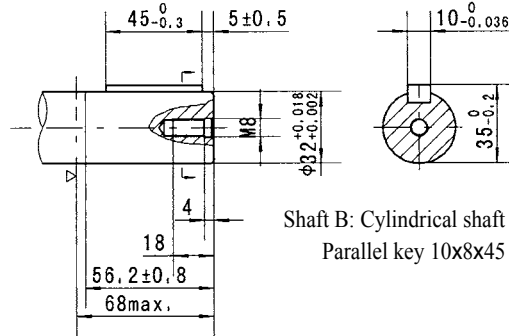

Shaft B: Cylindrical shaft ø32
Parallel key 10x8x45

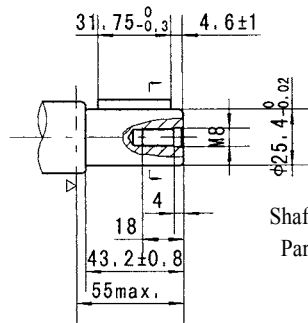

Shaft C: Cylindrical shaft ø25.4
Parallel key 6.35x6.35x31.75

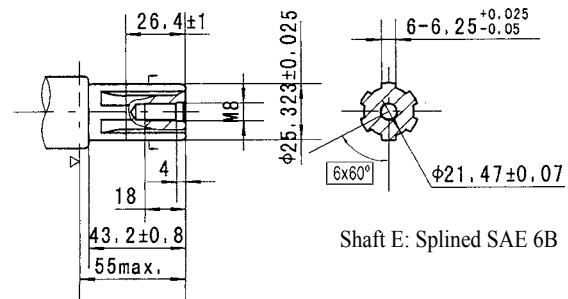

Shaft E: Splined SAE 6B

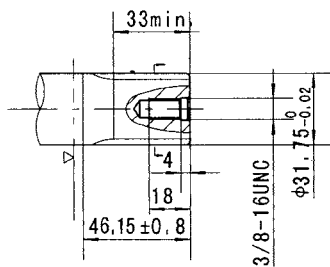

Shaft F: Splined
14-DP12/24

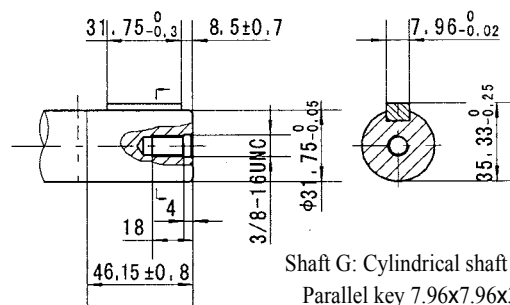

Shaft G: Cylindrical shaft ø31.75
Parallel key 7.96x7.96x31.75

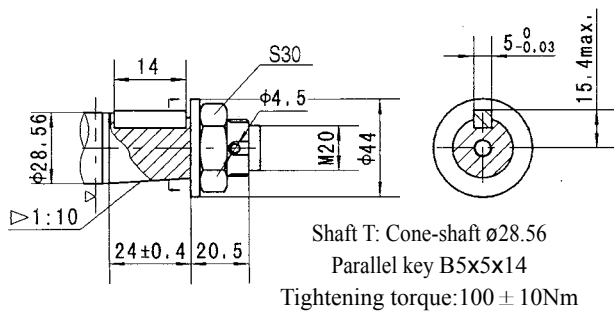

Shaft T: Cone-shaft ø28.56
Parallel key B5x5x14
Tightening torque: 100 ± 10Nm

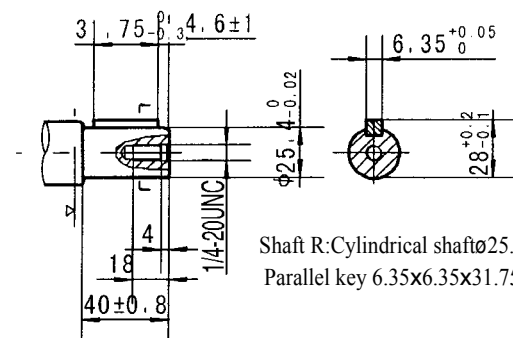

Shaft R: Cylindrical shaft ø25.4
Parallel key 6.35x6.35x31.75

▷ Motor Mounting Surface

SUFON MOTOR

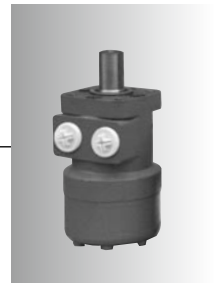

BMRS SHAFT EXTENSIONS DIMENSIDNS DATA

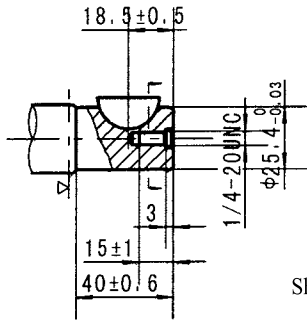

Shaft K: Cylindrical shaft $\phi 25.4$
Woodruff key $\phi 25.4 \times 6.35$

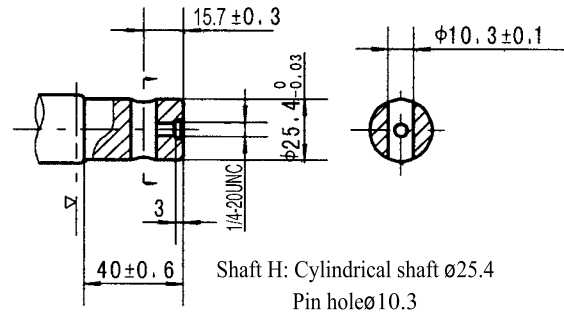

Shaft H: Cylindrical shaft $\phi 25.4$
Pin hole $\phi 10.3$

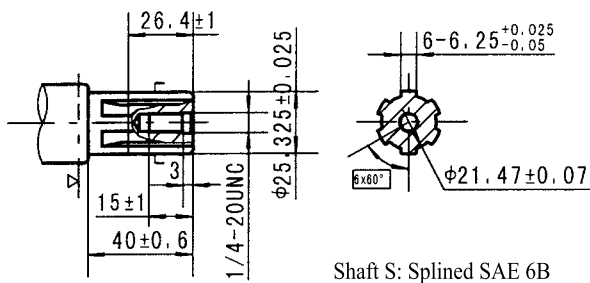

Shaft S: Splined SAE 6B

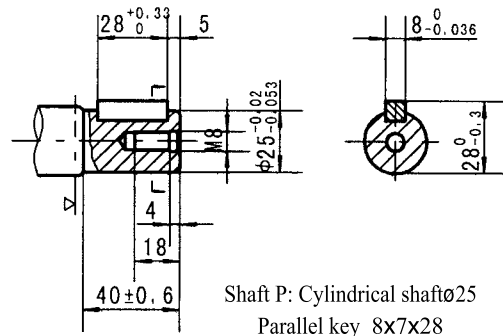

Shaft P: Cylindrical shaft $\phi 25$
Parallel key $8 \times 7 \times 28$

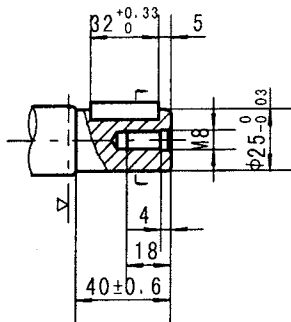

Shaft J: Cylindrical shaft $\phi 25$
Parallel key $7 \times 7 \times 32$

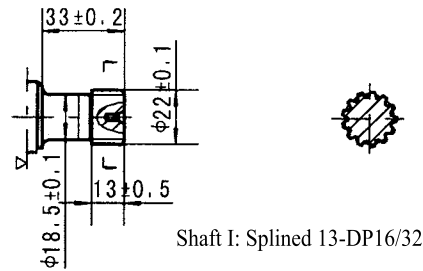

Shaft I: Splined 13-DP16/32

▷ Motor Mounting Surface

SUFON MOTOR

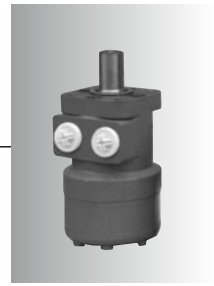

BMRS SHAFT EXTENSIONS DIMENSIONS DATA

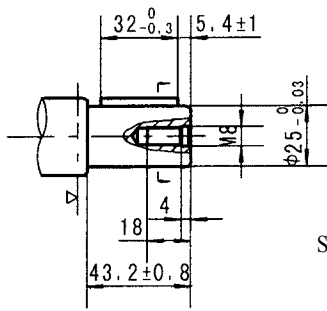

Shaft A: Cylindrical shaft $\phi 25$
Parallel key 8x7x32

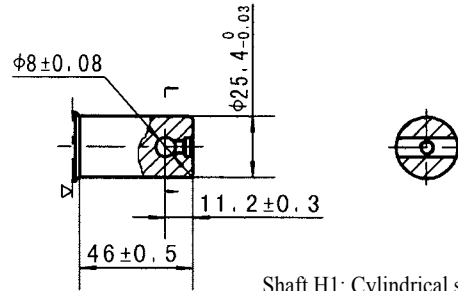

Shaft H1: Cylindrical shaft $\phi 25.4$
Pin hole $\phi 8$

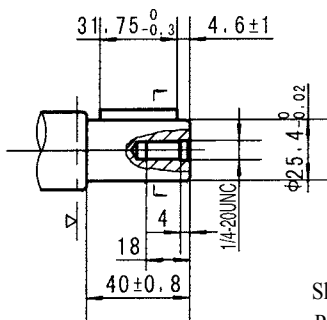

Shaft R: Cylindrical shaft $\phi 25.4$
Parallel key 6.35x6.35x31.75

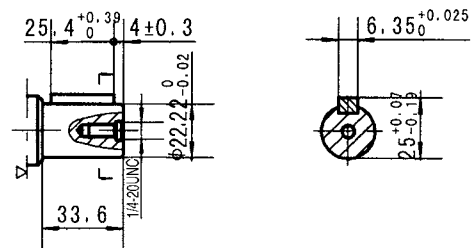

Shaft D: Cylindrical shaft $\phi 22.22$
Parallel key 6.35x6.35x25.4

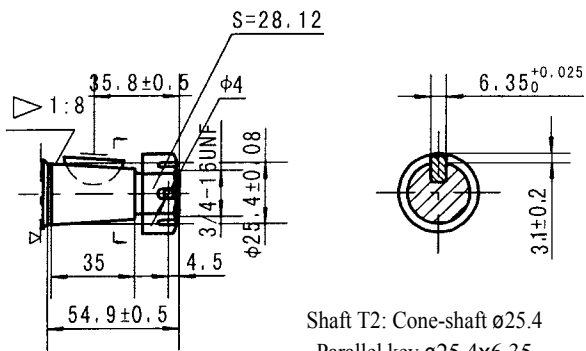

Shaft T2: Cone-shaft $\phi 25.4$
Parallel key $\phi 25.4 \times 6.35$
Tightening torque: $200 \pm 10 \text{ Nm}$

▷ Motor Mounting Surface

SUFON MOTOR



BMR, BMRS Series Hydraulic Motor

Permissible shaft seal pressure

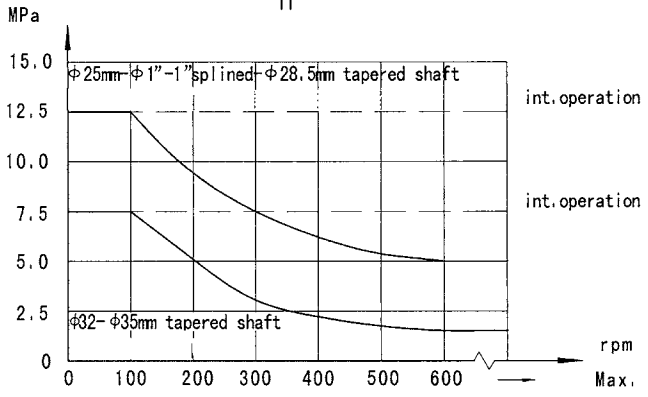
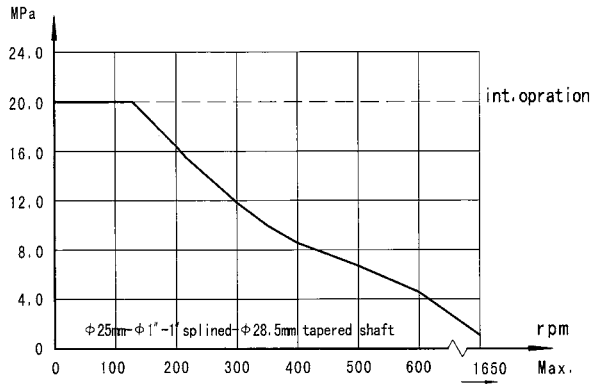
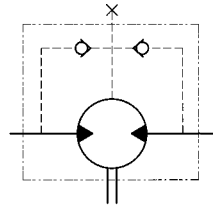

In applications without drain line, output shaft seal exceeds a bit of the pressure in the return line. When applications use the drain line, the pressure of output shaft seal equals the pressure in drain line.

Direction of shaft rotation: Standard

When facing shaft end of motor, shaft to rotate:
 Clockwise when port "A" is pressurized.
 Counter-clockwise when port "B" is pressurized.

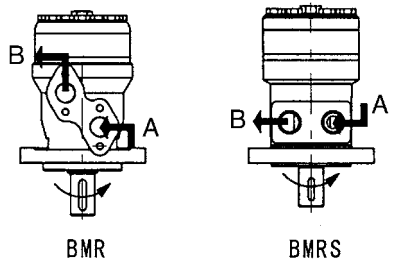

Status of the shaft's radial force

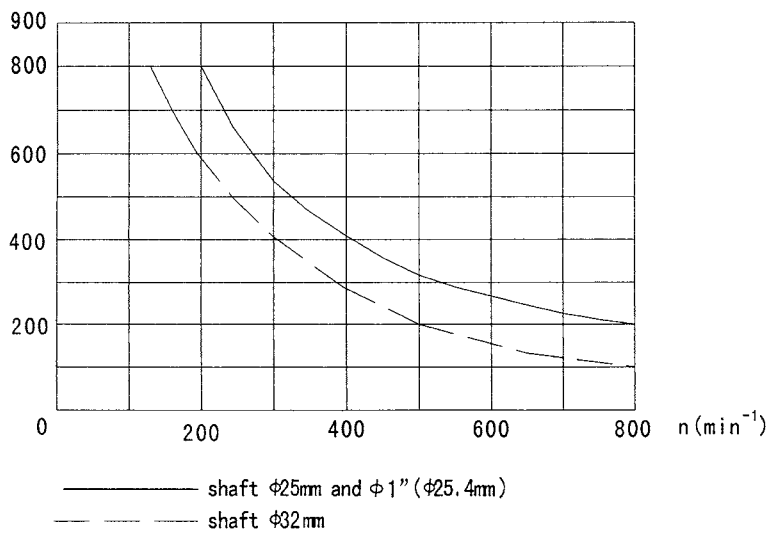

$$F_r = \frac{800, 25000}{n} \frac{1}{95+L} \text{ daN}$$

F_r =Radial Force (daN)
 L =Distance (mm)
 n =Speed (rpm)
 Rhomb-flange $L=30\text{mm}$
 Square-flange $L=24\text{mm}$

SUFON MOTOR

Order Information

1 2 3 4 5 6 7 8

BMR

Pos.1	2	3	4	5	6	7	8
Code	Disp.	Flange	Output Shaft	Port and Drain Port	Rotation Direction	Paint	Unusually Function
BMR	36	2-Ø13.5Rhomb-flange, pilot Ø82.5 × 8 4-Ø13.5Rhomb-flange, pilot Ø82.5 × 8 4-3/8-16 Square-flange, pilot Ø44.4 × 2.8 4-M10 Square-flange, pilot Ø44.4 × 2.8	A Shaft Ø25,parallel Key 8x7x32	G1/2 Manifold Mount 4-M8, G1/4 M22 × 1.5 Manifold Mount 4-M8, M14 × 1.5 S 7/8-14 O-ring manifold 4-5/16-18UNC, 7/16-20UNF 1/2-14 NPTF Manifold 4-5/16-18UNC, 7/16-20UNF PT(Rc)1/2 Manifold 4-M8, PT(Rc)1/4	Omit R Standard Opposite	No paint Blue Black Silver grey	Omit N 0 F LS Standard Big radial force No case drain Free Running Low Speed
	50		B Shaft Ø32,parallel Key 10x8x45				
	80		C Shaft Ø25.4,parallel Key 6.35x6.35x31.75				
	100		E Shaft Ø25.4,spined tooth SAE 6B				
	125		R Short shaft Ø25.4,parallel Key 6.35x6.35x31.75				
	160		F Shaft Ø31.75,spined tooth 14-DP12/24				
	200		FD Long shaft Ø31.75,spined tooth 14-DP12/24				
	250		G Shaft Ø31.75,parallel Key 7.96x7.96x31.75				
	315		T Cone-Shaft Ø28.56,parallel Key B5x5x14				
	375						

1 2 3 4 5 6 7 8

BMRS

Pos.1	2	3	4	5	6	7	8	
Code	Disp.	Flange	Output Shaft	Port and Drain Port	Rotation Direction	Paint	Unusually Function	
BMRS	36 50 80 100 125 160 200 250 315 375	2-Ø13.5Rhomb-flange, pilot Ø82.5 × 2.8 4-Ø13.5Rhomb-flange, pilot Ø82.5 × 2.8 4-3/8-16 Square-flange, pilot Ø44.4 × 2.8 4-M10 Square-flange, pilot Ø44.4 × 2.8	K Shaft Ø25.4,Woodruff Key Ø25.4 × 6.35	G1/2, G1/4 S 7/8-14 O-ring 7/16-20UNF (G1/4) P 1/2-14 NPTF, 7/16-20UNF (G1/4) T 3/4-16 O-ring, 7/16-20UNF R PT(Rc)1/2, PT(Rc)1/4 B4 Ø10 O-ring manifold 4x5/16-18, 7/16-20UNF B5 Ø10 O-ring manifold 4xM8, G1/4 M1 M18 × 1.5, M10 × 1 M2 M20 × 1.5, M10 × 1 M3 M22 × 1.5, M10 × 1	Omit R Standard Opposite	No paint Blue Black Silver grey	Omit N 0 F LS Standard Big radial force No case drain Free Running Low Speed	
			S Sub-shaft Ø25.4,spined tooth SAE 6B					
			A Shaft Ø25 , parallel key 8 × 7 × 32					
			R Shaft Ø25.4, parallel key 6.35 × 6.35 × 31.75					
			H Sub-shaft Ø25.4,Pin hole Ø10.3					
			H1 Shaft Ø25.4, pin hole Ø8					
			D Shaft Ø22.22, parallel key 6.35 × 6.35 × 25.4					
			I Shaft Ø22.22, spined tooth 13-DP16/32					
			T2 Cone shaft Ø25.4 , woodruff key Ø25.4 × 6.35					
			P Shaft Ø25,parallel Key 8 × 7 × 28					
			J Shaft Ø25,parallel Key 7 × 7 × 32					

Note:When the table is used, please fill the code of left rows in dash area and give us, which the code information is consists of construction, displacement, mounting flange, output shaft and ports. If the specification is not in the table or you have specific requirements, please contact us.